

Knox KN-ICE01 Ice Cream Maker Instruction Manual

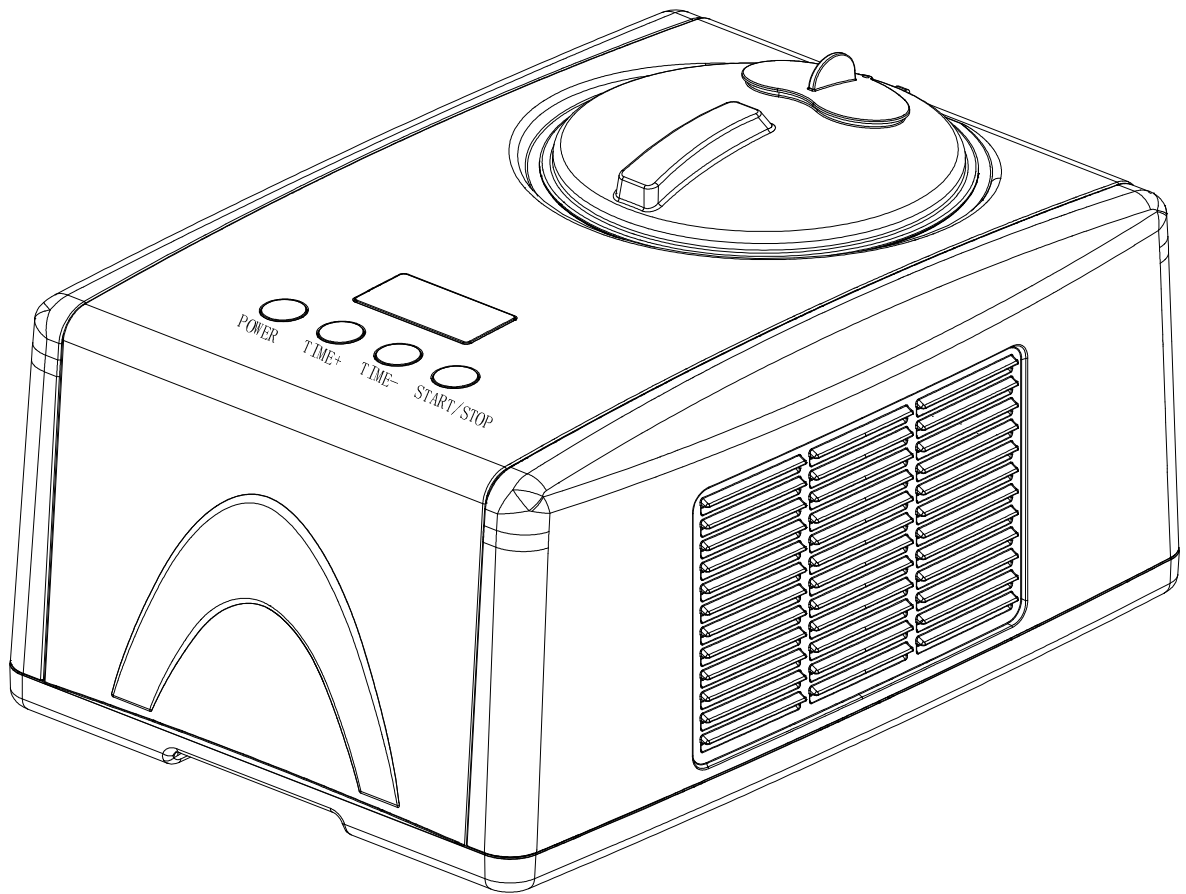

MODEL: KN-ICE01

Specifications

- Capacity: 50.721 Oz
- Voltage - 120V
- Frequency - 60 Hz
- Power Consumption - 150 W
- Cooling Temperature - 18~-35 Degrees
- Unit Dimensions - 15.8" x 11" x 9.6"
- Packing Dimensions - 18.5" x 13.7" x 13.9"

PARTS & FEATURES

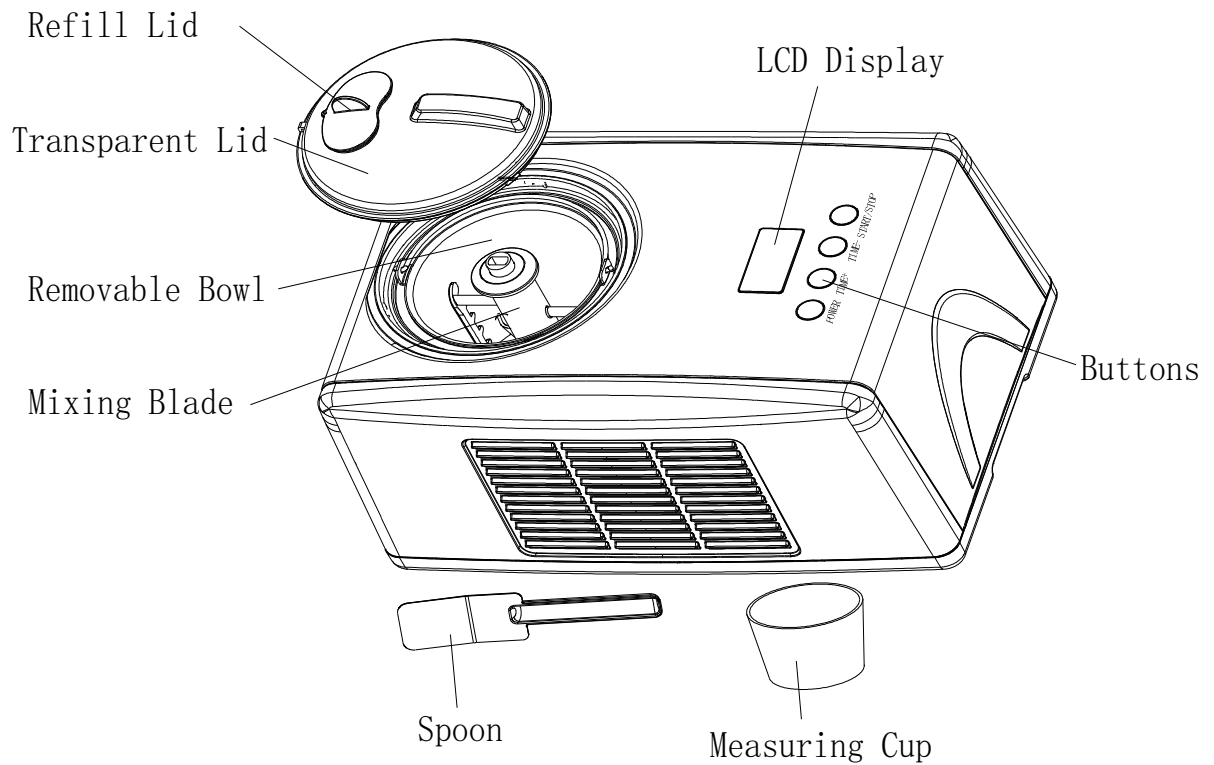

Making Ice Cream

1. Preparation

- a. **Cleaning** - Before use, thoroughly wash all parts that will come into contact with the ice cream ingredients. This includes the fixed bowl, removable bowl, mixing blade, transparent lid, refill lid, measuring cup, and spoon.
- b. **Prepare Ingredients** - Whether you use your own recipe or one included in this manual, prepare your ice cream mixture in a mixing bowl on the side. NOTE: Unlike other ice cream makers, you do not need to freeze the bowl in advance. The ice cream maker will take care of that as it makes your ice cream.

2. Assembly

- a. Make sure the ice cream maker is upright on a flat surface with the cord unplugged
- b. Place the removable bowl into the machine
- c. Put the mixing blade into the removable bowl (NOTE: Be sure the hole on the blade & motor axis line up. See Image Below)
- d. Place the transparent lid on top and lock it
- e. Place the refill lid onto the transparent lid

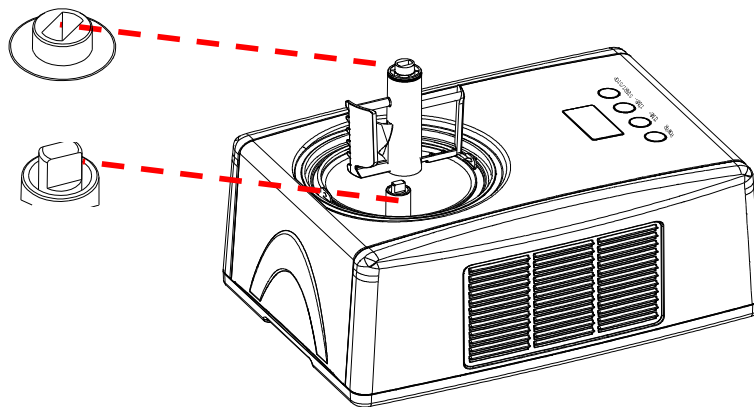

3. Steps / Functions

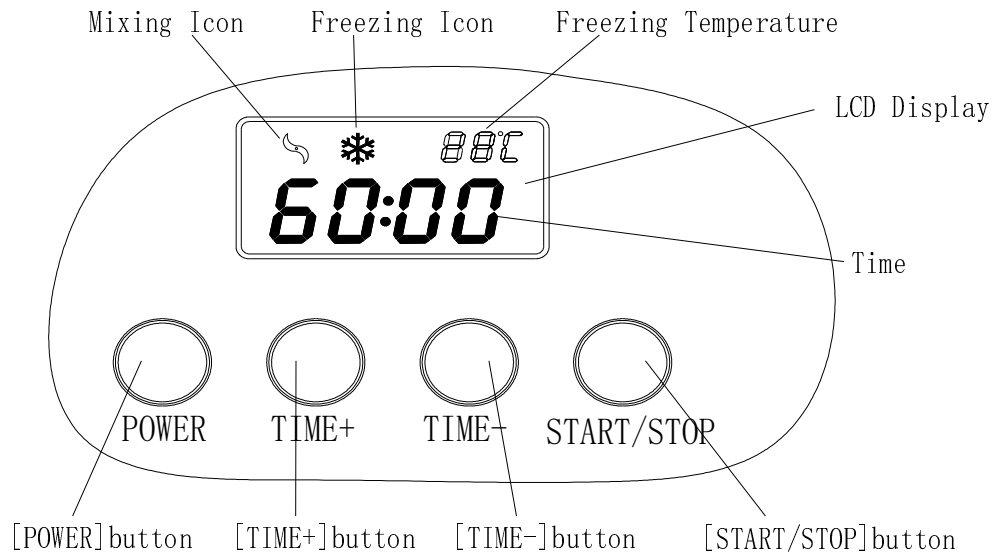

a. Buttons

- i. **[POWER] Button:** After connecting with the electricity, press the [POWER] button to turn the machine on. The LCD will display the default display time of “60:00”
- ii. **[TIME+], [TIME-] Buttons:** These buttons are used to add or subtract the amount of time the machine will run for. Pushing either button once will add or subtract one minute. Hold the button down to rapidly add or subtract time. The maximum time is 60:00, and the minimum time is 01:00.
 1. **Adding Time (After Operation Finished):** If a harder consistency of ice cream is desired after the operation has finished, more time can be added by pushing the [TIME +] button and then the [START/STOP] button once. The machine will continue to run down until the timer is finished.
- iii. **[START/STOP] Button:** After the desired time has been set, press the [START/STOP] button to begin the ice cream making process. Pressing the [START/STOP] button while the machine is still running will stop the blade, but not the compressor.
- iv. **Note:** Holding the [START/STOP] button for more than 3 seconds will reset the machine to its default settings. When this is done the LCD will display "00:00"

b. Extended Cooling Function:

- i. Once the process is complete the machine will wait 10 minutes and then automatically begin the cooling function. The cooling function will run for ten minutes and then automatically shuts off again. The machine will repeat this cycle for one hour after the ice cream making process has finished. It will then return to the initial default status.
- ii. **CAUTION:** To avoid an electric shock always remember to unplug from outlet when you serve the finished ice cream.

c. LCD Display Functions

- i. The LCD screen will display the remaining time prominently in the center of the screen
 - ii. The LCD screen will also show the temperature in the top right corner
 - iii. While the machine is running it will display both the FREEZING icon [❄] and MIXING [🌀] icon
 - iv. While it is performing the automatic cooling function the machine will display only the FREEZING [❄] icon .
- d. Motor Self-Protection Function** – If the ice cream becomes too hard, or the blending motor becomes otherwise blocked it will automatically shut off to avoid damage
- e. Controlling the Volume of the Ingredients** - To avoid overflow and waste, ensure the ingredients do not exceed 60% of the total capacity of the removable bowl. Ice cream ingredients will expand significantly when being made.
- f. Storage of Ice Cream** – Scoop out the ice cream to another container using plastic scoop or a wooden spoon. Do not use a metal scoop which can scratch the removable bowl.

Ice Cream Recipes

Vanilla Ice Cream

Ingredients

- 1 cup whole milk
- 1/2 cup granulated sugar
- 3/2 cups heavy cream, well chilled
- 1 – 2 teaspoons pure vanilla extract, to taste

Directions

- In a medium bowl, use a hand mixer or a whisk to combine the milk and granulated sugar until the sugar is dissolved (about 1 – 2 minutes on low speed.)
- Stir in the heavy cream and vanilla to taste.
- Turn machine on, pour mixture into freezer bowl through ingredient spout and let mix until thickened about 50 – 60 minutes.

Notes

- Makes eight 1/2-cup servings.
- Nutritional analysis per serving:
 - Calories 239 (68% from fat) / Carbs 17g / Protein 2g / Fat 18g / Sat. Fat 11g / Sodium 30mg

Variations

- **Mint Chip:** Replace the vanilla with 1 to 1-1/2 teaspoons pure peppermint extract (to taste). Chop your favorite 4-ounce bittersweet or semi-sweet chocolate bar into tiny uneven pieces. Add the chopped chocolate during the last 5 minutes of mixing.
- **Butter Pecan:** Melt 1 stick unsalted butter in a 10-inch skillet. Add 1 cup roughly chopped pecans and 1 teaspoon of salt. Cook over medium-low heat and stir frequently until the pecans are lightly browned. Strain the pecans out from the butter, allow the pecans to cool, and then add during the last 5 minutes of mixing (the butter will have a pecan flavor and may be saved for another use).
- **Cookies & Cream:** Add 3/4 cup coarsely chopped cookies or your favorite candy (chocolate chip, Oreos, etc.) during the last 5 minutes of mixing.

Basic Chocolate Ice Cream

Ingredients

- 1 cup whole milk
- 1/2 cup granulated sugar
- 240g or 8 ounces bittersweet or semi-sweet chocolate broken into 1/2-inch pieces
- 1 cup heavy cream, well chilled
- 1 teaspoon pure vanilla extract

Directions

- Heat the whole milk until it is just bubbling around the edges
- Use a blender or food processor fitted with a metal blade, to combine the sugar and chocolate until it is finely chopped.
- Combine the hot milk with the chocolate and stir until well blended and smooth.
- Transfer to a medium bowl and let the chocolate mixture cool completely.
- Stir in heavy cream and vanilla to taste.
- Turn the machine on, pour mixture into freezer bowl through ingredient spout and let mix until thickened, about 50 – 60 minutes.

Notes

- Makes eight 1/2-cup servings.
- Nutritional analysis per serving:
 - Calories 370 (60% from fat) / Carbs 34g / Protein 3g / Fat 25g / Sat. Fat 11g / Sodium 31mg

Variations

- **Chocolate Almond:** Add 1/2 teaspoon pure almond extract along with the vanilla. Add 1/2 - 3/4 cup chopped toasted almonds or chopped chocolate-coated almonds during the last 5 – 10 minutes of freezing.
- **Chocolate Cookie:** Add 1/2 - 1 cup chopped cookies during the last 5 minutes of freezing.
- **Chocolate Fudge Brownie:** Add 1/2 to 1 cup of chopped brownies bits. Add them during the last 5 minutes of freezing.
- **Chocolate Marshmallow Swirl:** When removing the ice cream to a container for freezing, layer it with dollops of your favorite chocolate sauce and scoops of marshmallow crème (fluff).

Fresh Strawberry Ice Cream

Ingredients

- 250g or 1 pint fresh ripe strawberries, stemmed and sliced
- 3/2 tablespoons freshly squeezed lemon juice
- 1/2 cup sugar
- 1 cup whole milk
- 1 cup heavy cream
- 1 teaspoon pure vanilla extract

Directions

- In a small bowl, combine the strawberries, lemon juice, and 1/3 cup of the sugar
- Stir gently and allow to the strawberries to marinate in the juices for 2 hours.
- In a medium bowl, use a hand mixer or a whisk to combine the milk and granulated sugar until the sugar is dissolved, about 1 – 2 minutes on low speed.
- Stir in the heavy cream plus any accumulated juices from the strawberries and vanilla. Turn the machine on, pour mixture into freezer bowl through ingredient spout and let mix until thickened, about 50 – 60 minutes.
- Add the sliced strawberries during the last 5 minutes of freezing.

Notes

- Makes eight 1/2 cup servings
- This ice cream will have a “natural” appearance of very pale pink; if a deeper pink is desired, sparingly add drops of red food coloring until desired color is achieved.
- Nutritional analysis per serving:
 - Calories 222 (61% from fat) / Carbs 20g / Protein 2g / Fat 15g / Sat. Fat 10g / Sodium 26mg

Fresh Lemon Sorbet

Ingredients

- 3/2 cups sugar
- 3/2 cups water
- 1 cup freshly squeezed lemon juice
- 1 tablespoon finely chopped lemon zest

Directions

- Combine the sugar and water in a medium saucepan and bring to a boil over medium-high heat.

- Reduce heat to low and simmer without stirring until the sugar dissolves, about 3 – 5 minutes.
- Cool completely. This is called a simple syrup. It can be made ahead of time and stored in a refrigerator.
- When cool, add the lemon juice and zest; stir to combine.
- Turn the machine on, pour the lemon mixture into freezer bowl through ingredient spout and mix until thickened, about 50 – 60 minutes.
- When zesting a lemon or lime use a vegetable peeler to remove the colored part of the citrus rind.

Notes

- Makes eight 1/2-cup servings.
- Nutritional analysis per serving:
 - Calories 204 (0% from fat) / Carbs 52g / Protein 19g / Fat 0g / Sat. Fat 0g / Sodium 2mg

Variations

- **Fresh Pink Grapefruit Sorbet:** Substitute 1-1/2 cups freshly squeezed pink grapefruit juice for the lemon juice, and 1 tablespoon finely chopped grapefruit zest for the lemon zest. Add 1/4 cup Orgeat Syrup to the mixture (Orgeat Syrup is used for cocktails such as a MaiTai or Scorpion and can be found with the drink mixers in most grocery stores).

Chocolate Frozen Yogurt

Ingredients

- 1 cup whole milk
- 180g or 6 ounces bittersweet or semisweet chocolate, chopped
- 2 cups low-fat vanilla yogurt
- 1/4 cup sugar

Directions

- Combine the milk and chocolate in a blender or food processor fitted with the metal blade until well blended and smooth, 20 – 30 seconds.
- Add the yogurt and sugar; process until smooth, about 15 seconds.
- Turn the machine on, pour mixture into freezer bowl through ingredient spout and let mix until thickened, about 50 – 60 minutes.

Notes

- Makes eight 1/2-cup servings.
- Nutritional analysis per serving:
 - a. Calories 222 (31% from fat) / Carbs 36g / Protein 3g / Fat 8g / Sat. Fat 64g / Sodium 46mg

IMPORTANT SAFETY NOTICES

- 1)** Read all instructions before using.
- 2)** Ensure the voltage is compliant with the voltage range stated on the rating label, and ensure the socket is in good condition.
- 3)** If the cord is damaged, it must be replaced by the manufacturer, a service agent, or a similarly qualified person in order to avoid malfunctions.
- 4)** Do not depend or leave on an incline greater than 45 degrees.
- 5)** Do not pour water on cord, plug or ventilation. Do not immerse the appliance in water or any other liquid.
- 6)** Unplug the appliance after using or before cleaning.
- 7)** Keep the appliance 6" away from other objects to avoid overheating.
- 8)** Do not use the accessories which are not recommended by Manufacturer.
- 9)** This appliance is not intended for use by persons (including children) with reduced physical, sensory or mental capabilities, or lack of experience and knowledge, unless they have been given supervision or instruction concerning use of the appliance by a person responsible for their safety. Children should be supervised to ensure that they do not play with the appliance.
- 10)** Do not use the appliance near open flames, hot plates or stoves.
- 11)** Wait at least 5 minutes between each batch to avoid damaging the compressor
- 12)** Do not insert metal objects or other electrical devices into the machine, doing so may cause a fire or short circuit.
- 13)** When removing the ice cream, do not knock the barrel or edge of barrel. Doing so may damage the machine.
- 14)** Do not switch on the power before installing the barrel or blender blade.

- 15)** Do not put the ingredients into freezer for pre-freeze. If ingredients are too cold or frozen it may block or damage the blending blade.
- 16)** Do not remove the blender blade when the appliance is plugged in or turned on.
- 17)** Do not use outdoors.
- 18)** Never clean with scouring powders or hard implements.
- 19)** Keep the instruction manual.